

THE KEYSTONE CHAPTER

of

The *Falcon* Club of America

Newsletter

Vol. 8, No. 2

April, 1995



DEDICATED TO PRESERVING

THE *FALCON* AUTOMOBILE

1960 - 1970 1/2

The Keystone Chapter of the Falcon Club of America was formed in 1988 to serve the geographical area consisting of Eastern Pennsylvania, Northern New Jersey and Southern New York.

## OFFICERS

### **PRESIDENT:**

Edward Snyder  
818 W. Callowhill Street  
Perkasie PA 18944  
(215) 257-2422

### **VICE PRESIDENT:**

Bruce Wolfe  
R.D. #1, Box 7940  
Grantville PA 17028  
(717) 469-7252

### **SECRETARY:**

Becky Wisneski  
R.R. #1, Box 9A  
Shickshinny PA 18655  
(717) 542-4059

### **TREASURER:**

Pam Wolfe  
R.D. #1, Box 7940  
Grantville PA 17028  
(717) 469-7252

### **EDITOR (PRO TEM):**

Frank Servas, Jr.  
P. O. Box 850  
Floral Park NY 11002  
(718) 343-2769

### **CHAPTER STORE MANAGER:**

Linda Wisser  
12 Magna Drive  
Coplay PA 18037  
(610) 262-6555

**DUES** are \$5.00 annually. Memberships expire with the Macungie meet in August. The Keystone Chapter Newsletter will be published with information from and for its members in the months of January, April, June, July, August and October. All items to be published should be sent to the editor.

## **PRESIDENT'S MESSAGE:**

The Keystone Chapter held its Annual Dinner this year at a different location: The Candlelight Inn Restaurant in Bethlehem, PA.

It was good to see everyone together again after our long winter months. The food was real good, and we all ate our share of the family style dinner. Afterward, we went over our calendar of events for the year, which promises to be a very busy season. After our dinner and general meeting, we viewed parts of the videotape of the 15th National Falcon Convention at Valley Forge, PA.

We have a volunteer for the position of editor. Starting with the June newsletter, Tom Baldwin will be our new editor for the Keystone Chapter Newsletter. Thank you Tom. Please send all information for publication to:

Tom Baldwin  
RR1 Box 231-C  
Hunlock Creek PA 18621  
(717) 256-3677

A list of committee chairs for the 6th Annual Regional is printed in this newsletter. Additional assistance is needed to make this event a success. Please call Bruce Wolfe if you would be able to assist during this event.

Our next get together is a Spring picnic at Millersburg PA. Hope to see you there.

Ed Snyder, President

The Falcon Club of America requires that all members of local chapters also belong to the National. Applications are available from the President or the Secretary and at our meets.

## TREASURER'S REPORT:

As of 3/18/95, the chapter has 1 new member, and 1 reinstatement, giving a total of 112 members.

Balance on hand (12/31/94)           \$4192.91

### Income:

New Member	5.00
Reinstatement	5.00
Dinner receipts	643.50
	-----
	653.50

### Expenses:

January newsletter	114.90
Dinner reminder postcard	22.05
Dinner Expense *	543.50
	-----
	680.45

Balance on hand (3/18/95)           \$4165.96

\* \$100 deposit for dinner already deducted.

Pam Wolfe, Treasurer

## NEW MEMBER:

Shirlee Schumann  
1985 Bristol Road  
Warrington PA 18976

## KEYSTONE CHAPTER NEWS:

Saturday, May 6. Spring picnic at the home of Rick & Lisa Adams in Millersburg, PA. A chicken bar-b-que is scheduled for 12:00 p.m. Please bring a covered dish to share. If you are planning to join us, please RSVP by April 28th at (717) 362-9236. Following lunch, we will be going on a short tour of Millersburg and the Historic Millersburg Ferry Boat, the only wooden paddle sternwheeler in the country in operation on the Susquehanna. We look forward to having a good time and another great year with the Falcon club. Directions:

From Route 81 -- turn West onto Route 209 or Route 25.

From Harrisburg -- take Route 225 North onto Route 209.

From Route 209: In Elizabethville take 209 West. Turn North (right) onto Botts Road (this is the second road on the right from Elizabethville). Proceed 1 1/2 mile, turn left onto Feidt Road and proceed three miles. The meet is at the 5th house after crossing the cement bridge.

From Route 25: From Berrysburg on Route 25 West, turn South (left onto Matterstown Road (which is 3 miles from Berrysburg). Proceed 1 1/2 miles until a "Y" in the roadway. Turn right at 2nd road on left. Meet is at the first farm on the right.

Friday - Sunday, June 9-11. **ALL-FORD NATIONALS** at Carlisle. An All-Ford Show with a class for Falcons. All cars pre-registered by December 31st will be in the Falcon class in our chapter area. Registration is still available at \$25 until April 15th. Call Carlisle Productions, (717) 243-7964 extension 4 for information. See room application for special Falcon club room rate at Days Inn - North, Harrisburg.

Saturday, June 24. Knoebels Grove Amusement Park, Elysburg PA.

Sunday, August 6. Das Awkscht Fescht, Macungie PA.

Sunday, August 20. 19th Annual Coopersburg Summer Fest,  
Coopersburg PA.

Friday-Saturday, September 8-9. Sixth Annual Regional Meet,  
Grantville PA.

## **SIXTH ANNUAL EASTERN REGIONAL MEET** **COMMITTEES**

Hospitality: Registration- Pam Wolfe, Lora Wolfe, Nancy Snyder,  
Paula Seibert

Club Store- Linda Wisser

Snack Table- Rick & Lisa Adams

Information Table-

Voting Ballots- Ed & Nancy Snyder

Parking Lot Layout- Dick Hostetter, Bruce Wolfe, Ed Snyder,  
Lora Wolfe

Games-

Trophies- Bill Wisser

Night Watch- Glenn Kuhn

T-Shirts & Caps- Glenn Kuhn

Door Prizes & Goodie Bags- Chet Wisneski

Raffle & 50/50 Tickets-

Banquet- Rick & Lisa Adams

Security during banquet- Bruce Wolfe

A little note to remind all club members about door prizes for our regional in September. If you would like to donate a prize or if you know a business that would be willing to donate, it would be greatly appreciated. Please direct any questions to Chet Wisneski (717) 542-4059.

Please bring all donations to the regional with name and address attached to the prize so proper acknowledgement can be sent. Thanks for your help.

### **TECHNICAL TIPS:**

Send your advice to the editor.

### **TECHNICAL HELP WANTED:**

I have a 1967 Futura Sports Coupe, and recently we discovered that the ignition switch seems to be missing a wire harness type plug (it would fit on the back of the switch to attach the wires behind the dash). Does anyone know if this piece exists, and if so, where one can be found? Also a 1967 wiring diagram would be a big help. Help would be appreciated. Respond to PFC Carman during the day at (703) 695-1051 or Ted Carman in the evening at (215) 257-3197. PFC Mark Carman, Bldg 406, Box 870, Fort Myer VA 22211-5050

Send your questions to the editor.

### **CARS FOR SALE:**

1967 Falcon, 2 door, 6 cylinder, stick shift. 20,000 miles, real good condition. \$3000 firm. Jay Trego (Philadelphia) (610) 933-9745.

Send your ads to the editor.  
(include full description- year,  
body style, 2 or 4 door, color,  
engine, tranny, price, etc.)

### **CARS WANTED:**

### **PARTS FOR SALE:**

Send your ads to the editor.  
(Please indicate a price for  
each item offered.)

### **PARTS WANTED:**

### **SERVICES OFFERED:**

### **SERVICES RECOMMENDED:**



The *Falcon* Club of America

SIXTH ANNUAL EASTERN REGIONAL FALCON MEET

Grantville, Pennsylvania  
September 8-9, 1995

SHOW REGISTRATION & BANQUET RESERVATION FORM

Name \_\_\_\_\_ Spouse/Guest \_\_\_\_\_

Address \_\_\_\_\_

City \_\_\_\_\_ State \_\_\_\_\_ Zip \_\_\_\_\_

Phone # (\_\_\_\_) \_\_\_\_\_ FCA # \_\_\_\_\_ Local Chapter \_\_\_\_\_

Falcons:

Car #1: Year \_\_\_\_\_ Model \_\_\_\_\_ Body Style \_\_\_\_\_

Number of Doors \_\_\_\_\_ Color \_\_\_\_\_ Class \_\_\_\_\_

Car #2: Year \_\_\_\_\_ Model \_\_\_\_\_ Body Style \_\_\_\_\_

Number of Doors \_\_\_\_\_ Color \_\_\_\_\_ Class \_\_\_\_\_

Registration:

Without Car: \$12 (after August 15)  
\$8 (before August 15) \_\_\_\_\_

With Car: first car \$15 (after August 15)  
\$10 (before August 15) \_\_\_\_\_

additional cars \$12 each (after August 15)  
\$8 each (before August 15) \_\_\_\_\_

Swap Space: \$25 (after August 15)  
\$15 (before August 15) \_\_\_\_\_

Banquet:

Saturday, September 9:

Dinner \$25 adult (per person) (# \_\_\_\_\_)

\$13 child (up to 12) (# \_\_\_\_\_)

Clothing:

T-Shirts (Specify Sizes: \_\_\_\_\_)

(S, M, L, XL \$10 ea, XXL \$11 ea, XXXL \$12 ea)

Caps \$8 ea (Quantity: \_\_\_\_\_)

Grand Total \_\_\_\_\_

(Check payable to Keystone Chapter)

Send to: Pam Wolfe, R.D. #1 Box 7940, Grantville PA 17028  
(717) 469-7252





The *Falcon* Club of America

SIXTH ANNUAL EASTERN REGIONAL FALCON MEET

Grantville, Pennsylvania  
September 8-9, 1995

HOTEL RESERVATION FORM

RESERVATION REQUEST

**Holiday Inn**

HERSHEY-HARRISBURG  
EXIT 28/I-81, GRANTVILLE, PA 17028  
(717) 469-0661

CHECK IN TIME - 3:00 PM  
CHECK OUT TIME - 12:00 NOON

No. of Rooms \_\_\_\_\_ How Many Singles \_\_\_\_\_ Doubles \_\_\_\_\_ Special Requests \_\_\_\_\_

Arrival Date \_\_\_\_\_ Departure Date \_\_\_\_\_ \*Time of Arrival \_\_\_\_\_

\*Rooms held only until 6:00 PM unless guaranteed by one night's deposit or major credit card.

Group Name Falcon Club

Name(s) \_\_\_\_\_

Address \_\_\_\_\_ Special Group Rate \$75 sgl/dbl

Phone ( ) \_\_\_\_\_

Credit Card Name \_\_\_\_\_ # \_\_\_\_\_ Exp. \_\_\_\_\_

- These special accommodations and rates will be available up to two weeks prior to your gathering after which time these rooms will return to the hotel for their normal sale.
- Reservations will be held until 6:00 PM unless guaranteed. If guest does not arrive, first night will be billed and reservation for the following night(s) cancelled.

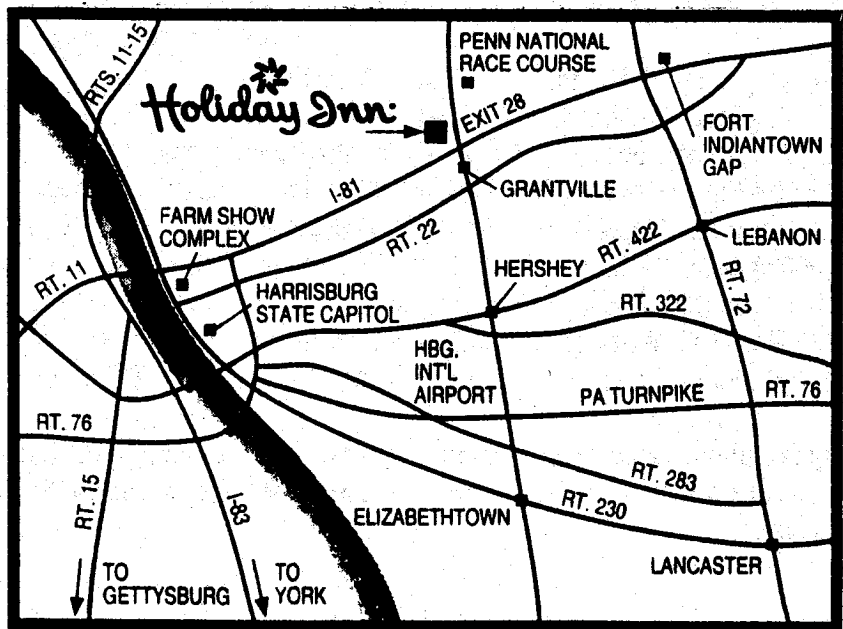

## CHAPTER STORE:

Keystone Chapter items displaying our logo are available at our meets:

T-shirts are available in small, medium, large and extra-large sizes. Cost \$8.00

Caps are adjustable to size. Cost \$5.00

Keystone coffee mugs. Cobalt blue with Keystone logo in white. Cost \$4.00

Chapter jackets must be ordered in advance. Color is burgundy, and jacket will be personalized with your first name. Send jacket order with remittance, sizes and personalization to:

		Big A, Inc.
Small	36-38	Glenn L. Kuhn
Medium	40-42	Drawer E
Large	44-46	Fayetteville PA 17222
Extra Large	48-50	(717) 352-2544
Extra Extra Large	52-54	Cost \$35.00

### Previous Regional & National Shirts and Caps:

2nd Regional T-Shirts.	Cost	\$10.00
3rd Regional T-Shirts.	Cost	\$10.00
3rd Regional Caps.	Cost	\$8.00
4th Regional T-Shirts.	Cost	\$10.00
4th Regional Caps.	Cost	\$8.00
5th Regional T-Shirts.	Cost	\$10.00
5th Regional Caps.	Cost	\$8.00
15th National T-Shirts.	Cost	\$10.00
15th National Caps.	Cost	\$8.00

Inquire about sizes available on T-shirts. Please include \$2 extra per item on mail orders, and send to Linda Wisser, Chapter Store Manager.

## ANNUAL DINNER REPORT

A total of 39 members and friends attended our seventh annual dinner at the Candlelight Inn in Bethlehem on March 18th:

Rick & Lisa Adams  
Tom & Gloria Baldwin  
Ted Carman & Guests  
Rich Hostetter & Paula Seibert  
Roy & Betty Hunsberger  
Tom & Michelle Jones  
Bruce & Joan Kichline  
Mike & Ann Kirsch  
Roy Kolb  
Gerald Kratz  
Jerry & Linda Kratz  
Harold Krause & Pat Zentner  
Glenn Kuhn & Barb Sellers  
Dennis Palatucci  
Frank & Ginny Servas  
Ed & Nancy Snyder  
Todd Spencer  
Chet & Becky Wisneski  
Bill & Linda Wisser  
Bruce & Pam Wolfe

Those who attended enjoyed an "all you can eat" meal of fresh fruit cup, tossed salad, roll, whipped potatoes, roast beef and roast turkey, vegetable and ice cream. Afterward, during the business meeting reports were made by the officers, and future chapter events were discussed. The tape of the 1994 National meet in Valley Forge was shown in part. The pleasant evening concluded about 10 p.m.

Treasurer's report for our seventh year through 12/31/94.

Balance on Hand 12/31/93	1416.09
Income:	
Dues for 19 new members	95.00
Reinstatements	20.00
Renewals	440.00
Donations and Contributions	244.00
50/50 Raffles	129.00
Dinner Receipts	742.50
Dinner Deposit (1993) refund	80.00
Chapter Store Receipts	888.00
Profit from National	2737.53
	-----
Total	5376.03
Expenses:	
Newsletters, envelopes, cards and postage	392.24
Dinner Expense	736.15
Various Picnics	252.10
Trophy Sponsorship	108.12
Cookbook expense	629.48
Purchase of National Items	198.30
Regional Videotapes	131.80
Sympathy Bouquet	40.07
Misc., Checking Acct	10.95
Dinner (1995) Deposit	100.00
	-----
Total	2599.21
Balance on Hand 12/31/94	4192.91

Pam Wolfe, Treasurer

# AREA MAP: MILLERSBURG

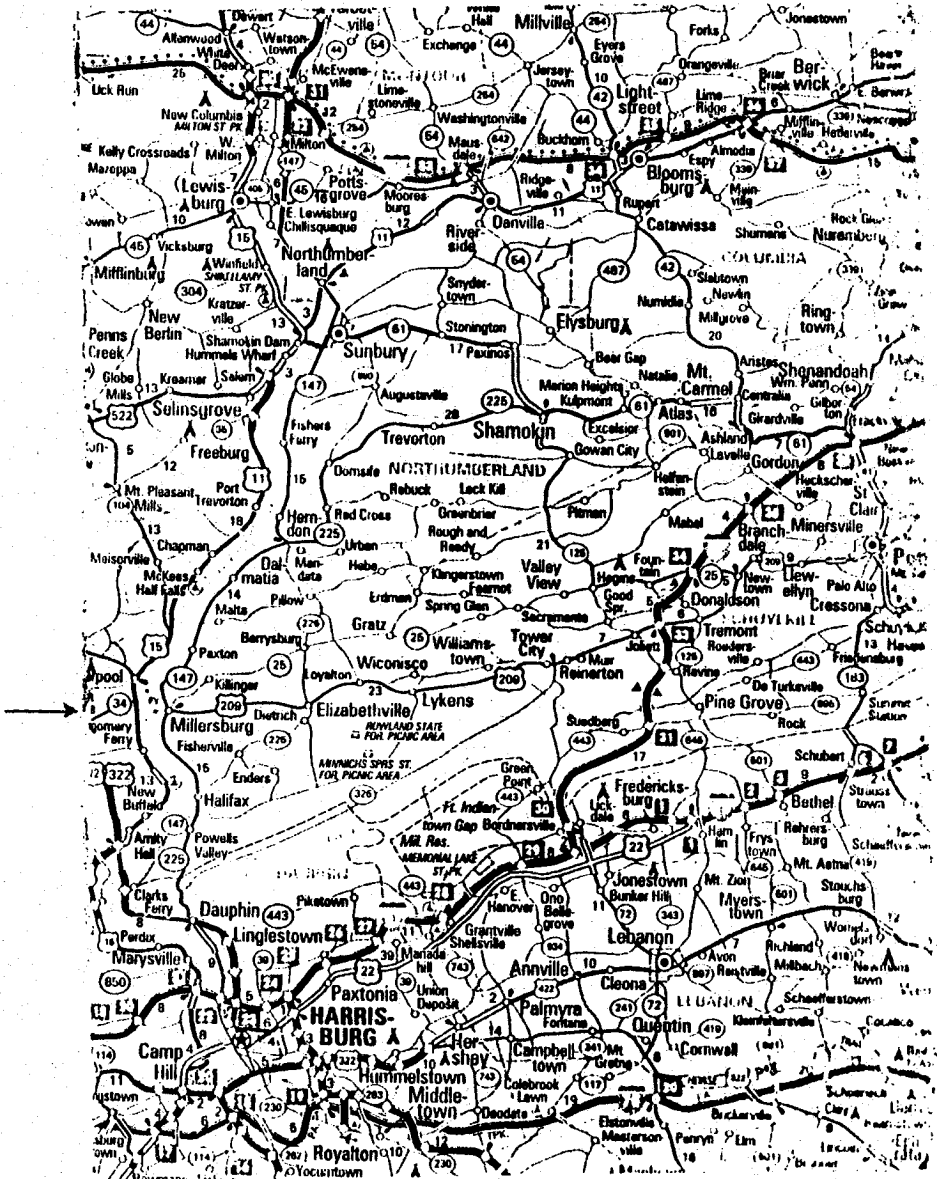

**CAR FOR SALE:** 1968 Falcon 4 door sedan. One family owner, V8 auto, 34,300 miles. Run regularly. Very good condition. No rust with new paint job in original color- blue pearl. \$3,000 OBO. Marlene Rafner, 30 N. Waterloo Road, Devon PA 19333 (610) 687-3228.

## 392 WINDSHIELD WIPER PARK SWITCH ADJUSTMENT

(1965 Single Speed Wiper Motor)

Improper or erratic parking of the windshield wiper blades or wipers that will not shut off can be caused by a maladjusted park switch.

### A. WIPER MOTOR PARK SWITCH TEST (MOTOR IN VEHICLE)

- Should either of these conditions be encountered, the park switch test shown on Fig. 9 should be performed.
- With the motor connected per Fig. 9 it should move to the park position. If it does, the motor is all right and the fault lies in the panel switch or wiring.

### WARRANTY STATUS – REIMBURSABLE

Oper. SP-17508-A-65

Time: 0.3 hrs.

If the motor does not park, proceed with the following park switch adjustment.

### B. WIPER MOTOR PARK SWITCH ADJUSTMENT

#### 1965 Falcon (Remove motor from vehicle)

1. Remove bolts, wiper motor, and bracket to dash panel. Lower and disconnect wiper links and remove motor and bracket from the vehicle.

2. Remove motor through bolts and remove motor cup and armature.

3. Rotate output shaft until park switch lower contacts are firmly closed. (See Fig. 9.)

### PARK SWITCH TEST

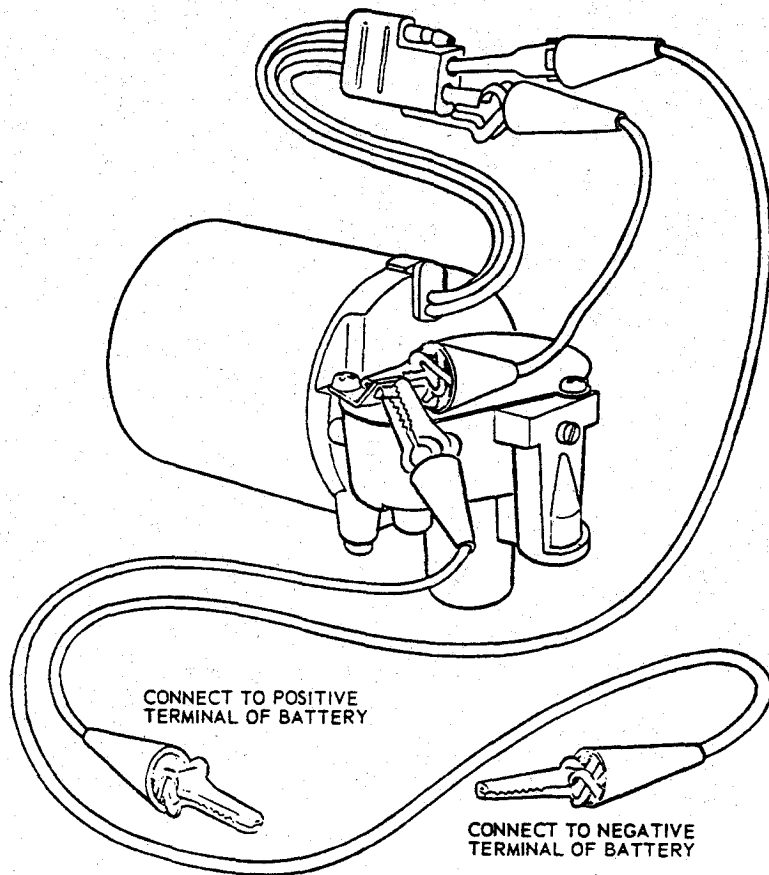

Fig. 9 – (Article 392)

lower contacts are firmly closed. (See Fig. 9.)

Fig. 9 - (Article 392)

4. Rotate adjusting screw clockwise until the park switch lower contacts just open.

5. Rotate adjusting screw counter-clockwise one full turn.

6. Check bridge (See Fig. 10) to assure that legs are contacting the brush card when lower contacts are closed. If not, carefully bend the upper blade for proper contact.

7. Install armature, motor cup and through bolts.

8. Install the motor and bracket assembly to dash panel, connect links and wires.

9. Check operation of wiper motor.

Oper. SP-17508-A1-65

Time: 0.3 hrs.

Should this fail to correct the condition, proceed with instructions in appropriate Shop Manuals.

## 468 ACCELERATOR LINKAGE STABILIZER ROD

(1966 Falcons, Comets, and Fairlanes)

Service procedures have been revised on 6 and 8-cylinder engines equipped with accelerator linkage stabilizer rods. Whenever engine repairs or service adjustments are made which require raising the engine even a slight amount, the accelerator linkage stabilizer rod should be disconnected. This will prevent the rod from becoming bent, which in turn causes improper operation of the accelerator linkage.

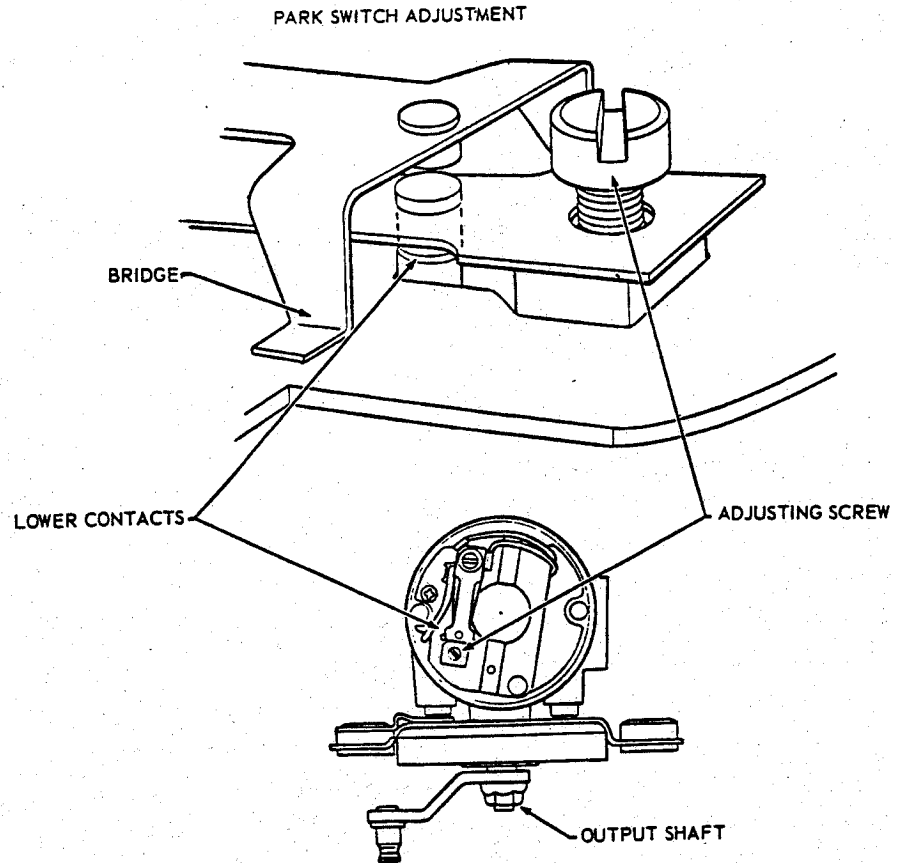

Fig. 10 - (Article 392)

Group Name/# Falcon Club Group Dates June 9, 10, + 11, 1995

Group Rates: Single \$49 Double \$49 Extra Person \_\_\_\_\_

Name \_\_\_\_\_

Address \_\_\_\_\_

City \_\_\_\_\_ State \_\_\_\_\_ Zip \_\_\_\_\_

Day Phone # \_\_\_\_\_ Evening Phone # \_\_\_\_\_

Name(s) of person(s) sharing room(s): \_\_\_\_\_

Number of rooms: \_\_\_\_\_

Date of Arrival \_\_\_\_\_ Date of Departure \_\_\_\_\_

Request Non-Smoking Room

Smoking

(Based upon availability)

### PAYMENT METHOD

First night's deposit enclosed

Amount \_\_\_\_\_

Guaranteed By Credit Card No. \_\_\_\_\_ Exp. Date \_\_\_\_\_

AMEX

VISA

MASTERCARD

DINERS CLUB

OTHER \_\_\_\_\_

Cancellation Policy: 6 P.M.

Check-In: 2 P.M.

Check-Out: 12:00 Noon

717-233-3100

Your Host has reserved a block of rooms to be held until 3 weeks prior to the event.  
Reservations received after that date will be honored on a first come basis at regular rates.  
Please make your reservations promptly by using this form. Thank You!

**DAYS INN - NORTH**  
3919 N. FRONT STREET  
HARRISBURG PA 17110