

THE KEYSTONE CHAPTER
of
THE FALCON CLUB OF AMERICA

Newsletter

Vol. 4, No. 2

April, 1991



DEDICATED TO PRESERVING

THE FALCON AUTOMOBILE

1960 - 1970 1/2

The Keystone Chapter of the **Falcon Club** of America was formed in 1988 to serve the geographical area consisting of Eastern Pennsylvania, Northern New Jersey and Southern New York.

OFFICERS

PRESIDENT: Edward Snyder
818 W. Callowhill Street
Perkasie, PA 18944
(215) 257-2422

VICE PRESIDENT: Robert Vaughn
1123 Washington Avenue
Allentown, PA 18103
(215) 435-4849

SECRETARY: Marin F. Ennis
1405 Dogwood Drive
West Lawn, PA 19609
(215) 678-2997

TREASURER: Virginia C. Servas
P. O. Box 850
Floral Park, NY 11002
(718) 343-2769

EDITOR: Frank Servas, Jr.
P. O. Box 850
Floral Park, NY 11002
(718) 343-2769

DUES are \$5.00 annually. The Keystone Chapter Newsletter will be published with information from and for its members. All items to be published should be sent to the editor.

Newsletter April 1991 Whole Number 17

PRESIDENT'S MESSAGE:

Our annual chapter dinner held at Meyer's restaurant on March 16th turned out very well. The weather was great to bring out the **Falcons** for the first run of the year.

We were pleased that Ed Melefsky could attend, and explain the history of the Spare Parts TV show to our group. In addition to the tape of the recent program in which Marin Ennis represented our chapter, we also enjoyed the tape of the Grantville meet with the **Falcon** cruise around the park. Thanks to Marin and Bruce & Pam Wolfe for these tapes.

Other matters discussed at the dinner are summarized elsewhere in this newsletter. My thanks to all who helped with door prizes and attended to make the dinner a big success.

Ed Snyder, President

SECRETARY'S REPORT:

Many thanks to all who attended the dinner at Meyer's. Besides the nice turnout, there was a healthy and constructive discussion within the membership about how future chapter functions should be conducted. Let's keep it up as the more ideas we hear from you the better our chapter can become.

For those who couldn't make it to the dinner, the possibility of a regional meet in September was discussed. At this stage of the game, we'll have to work fast to pull it off. So if you have any ideas about how to help us out, your chapter officers are all ears! We've had two great regionals thus far- Let's all get together to make the third one another success. See you at Perkasio.

Marin Ennis, Secretary

TREASURER'S REPORT:

As of 3/16/91, the chapter has 4 new members. The chapter has lost 13 members through non-renewal, and now has a total of 77 paid members.

Balance on hand (12/31/90) \$833.80

Income:

Dues (4 new members)	20.00
Renewals	15.00
Contributions	6.50
Dinner Receipts	681.50
Profit on sale of chapter store items	40.00

	763.00

Expenses:

Dinner expenses *	605.07
Coffee mugs	349.10
January newsletter	25.42
Postcard reminder	16.15
President's postage	4.50

	1000.24

Balance on hand (3/16/91) \$596.56

* \$80 deposit for dinner previously deducted.

Virginia Servas, Treasurer

MEMBERSHIP YEAR:

The cutoff for the membership year has been established as the Macungie meet of each year.

EDITOR'S MESSAGE:

In the last newsletter, I tried to get too much on one page, and in the article on directional signals, the chart of bulb equivalents was printed over the fold. I found this of interest, and have reprinted it at the end of this newsletter.

Our third annual chapter dinner was well attended. Forty-seven persons were there, an increase of 7 from last year.

May 18th is the Perkasio meet. Remember to bring some parts for sale or trade to make this swap meet a success.

The Eastern Regional meets were held in Livingston NJ in 1989 and Toms River NJ in 1990. A suitable site has not yet been found for a 1991 fall regional meet. As it is desired for this to be a three chapter sponsored meet, the most central location would be in New Jersey. The ideal location would have motel facilities at a reasonable rate, space for the banquet, and an adequate parking area for 50 to 75 show cars (figuring 1 1/2 spaces per car). If anyone has any suggestions for a site that has a September opening, please contact show chairman Chris Scioscia, 50 Spring Street, Bloomfield NJ 07003, (201) 743-7245

The next newsletter is planned for June. Since it will contain information for the Grantville meet on June 15th, it must be mailed early, and I ask that all submissions for that newsletter reach me by the Perkasio meet on May 18. See you there.

Frank Servas, Editor

The **Falcon Club of America** requires that all members of local chapters also belong to the National. Applications are available from the President or the Secretary and at our meets.

KEYSTONE CHAPTER NEWS:

Saturday, May 18. Meet at Perkasio, PA starting at 9 a.m. in Lake Lenape Park. This will also be a swap meet. Be sure to bring along any extra parts you may have for sale or trade. Picnic tables are available, and you can use charcoal. No beer or alcoholic beverages are permitted in the park. Pizza and hoagies are available nearby. A meeting will be held at 1 p.m. to discuss chapter matters. Directions to the park appear elsewhere in this newsletter.

Saturday, June 15. Meet at Memorial Lake State Park, Grantville, PA. Take route 81 to exit 29: route 934 North. The park is 1 1/2 miles from the exit. No admission charge. This will be a chapter picnic. Hot dogs, hamburgers, rolls and soda will be furnished by the chapter. Bring a covered dish or dessert to share. Respond to Bruce & Pam Wolfe (717) 469-7252 by June 8th, giving the number in your party. Further details and a map will be in the June newsletter.

Sunday, August 4. Meet in conjunction with the Macungie (PA) Show. Pre-registration only. Election of officers will take place at this meet. Memberships expire with this meet, and dues for the following year can be paid at this time. If you pre-registered last year, you should receive an application in the mail.

NEWS FROM NEARBY CHAPTERS:

MASON-DIXON CHAPTER

Sunday, April 21. Seaford, Delaware, 10 a.m.
at the PK Video Super Store, Stein Hwy (Route
20) and Nylon Blvd.

Saturday, May 18. Denton, Maryland, 9 a.m.
at Smith Ford, Route 404.

Information on both events from Bob Gerke
(302) 337-8175.

NORTHEAST CHAPTER

Sunday May 5. Rhinebeck, NY, at Dutchess
County Fairgrounds, Route 9. For info, call
Tom Massarelli (914) 471-7769.

OTHER EVENTS OF INTEREST:

Sunday, May 5. Blue Mountain Classics at
Macungie PA. Pre-registration \$7. For info,
call Bonnie Rohn (215) 759-5969.

Sunday, June 16. Palmerton, PA. At the Park
Area, Delaware Avenue. Pre-registration \$6.
For info, call Cindy Berger (215) 826-5650.

Friday & Saturday, June 28,29. Macungie, PA.
One time special event hosted by the
Ontelaunee Region AACA. Registration
Chairman: Roland Kotzmann (215) 395-4716.

Thursday, July 4. Virginville, PA. At the
Fire Company, Route 143. Pre-registration
\$4. Info: (215) 267-2735.

NEW MEMBERS:

Lee C. Ferrier
210 Windsor Street
Reading, PA 19601

Richard Grant
R.D. #5 Box 190
Jersey Shore, PA 17740

Mark A. Piccolino
248 S. Atlantic Avenue
Pittsburgh, PA 15224

Richard M. Riley
201F Brighton Avenue
Mt. Penn, PA 19606

558 EXHAUST "BOOM" NOISE AND/OR VIBRATION AT 20-35 MPH UNDER ACCELERATION

(1966 Falcons 6 Cylinder Automatic
Transmission Sedans Built Before
October 15, 1965)

An objectionable exhaust "boom" noise or vibration may be experienced on some 1966 Falcon sedans at road speeds of 20 to 35 MPH under accelerating load (engine RPM 1500-1800).

Field experience has shown that "boom" noise or vibration can be reproduced for verification by performing a stall test on units built before 10-15-65. During the stall test the resonant frequency of the exhaust pipe will occur, thus producing the objectionable vibration.

On a customer complaint basis only this problem can be reduced to an acceptable level by installing a laminated reinforced inlet exhaust pipe - (part #C6DZ-5246-E, Class "C").

The procedure used to remove and replace the muffler inlet exhaust pipe is outlined in the 1966 Falcon Shop Manual.
WARRANTY STATUS - REIMBURSABLE
Oper: 5246-A

Time: Std. allowance

456 CONVERTING 144 CID ENGINE TO 170 CID ENGINE

(All 144 CID Engines)

Converting a 144 CID engine to a 170 CID engine can be satisfactorily accomplished, but short-cut conversions must be avoided. Any attempt to use the 144 CID cylinder head, or any of certain other components, will result in unsatisfactory performance and ultimate failure.

If a 144 CID cylinder head is installed on a 170 CID short block, the compression ratio will immediately rise from 8.7 to 1 to approximately 10 to 1. Use of an extra head gasket to reduce this compression would have no appreciable effect, and would be conducive to water and/or compression leaks. Thus, a 170 CID head must be used on a 170 short block. It is most important to fully understand the basic differences between the two engines to realize what can or cannot be done. Note the following:

Crankshaft	
144 CID	170 CID
Stroke - 2.50	2.94
Connecting Rods	
Length - 4.854	4.714
4.856	4.716
Pistons	
Regular Skirt	Extended Skirt

Any attempt to rework a 144 CID carburetor to be used on a 170 CID engine is not recommended.

Although the distributors are interchangeable, they must be recalibrated to conform to the specified advance curve for the 170 CID engine. It should also be noted that the distributor pilot bore bushing to be found in the blocks of recent manufacture may or may not have to be removed according to whether a 1/4 in. or 5/16 in. hex drive distributor and intermediate shaft are used.

If conversions are made without respect to the above, excessive compression, overheating, rough operation, detonation, and burned pistons will result. Likewise, any attempt to convert a 170 CID engine to a 144 CID engine would involve a similar though different set of serious problems. Any conversion attempt should of course take into consideration compatibility of head and block components as to whether hydraulic or mechanical valve lifters are used.

It should be noted that Ford authorized engine rebuilders have been approved to make this conversion.

CHAPTER STORE:

Keystone Chapter items displaying our logo are available at all of our meets:

T-shirts are available in small, medium, large and extra-large sizes. Cost \$8.00

Caps are adjustable to size. Cost \$5.00

Keystone coffee mugs Cost \$4.00

Chapter jackets must be ordered in advance. Color is burgundy, and jacket will be personalized with your first name:

Small	36-38	
Medium	40-42	
Large	44-46	
Extra Large	48-50	
Extra Extra Large	52-54	Cost \$35.00

Send jacket order with remittance, sizes and personalization to:

Big A, Inc.
Glenn L. Kuhn
Drawer E
Fayetteville, PA 17222
(717) 352-2544

TECHNICAL TIPS:

Send your advice to the editor.

TECHNICAL HELP WANTED:

Send your questions to the editor.

CARS FOR SALE:

1965 hardtop. V8, auto, disc brakes, very good body & interior, inspected. Asking \$2500.

1964 Futura conv, 6 cyl, auto. New top & inspection, runs excel, needs little rest. Asking \$3000.

1963 Futura, 2 door, 6 cyl, auto. Very good body, runs good, garage kept, needs little interior work. Asking \$1000.

1963 Sprint V8, 4 spd. Off road past 7 years. Needs restoration, but all there \$1600.

1962 2 door wagon, 6 cyl. Needs restoration Asking \$350.

Above cars: George Rokita, RD#3 Box 167, Elverson, PA 19520 (215) 286-0299.

1964 Futura conv, was 260, 4 spd, has 6 cyl, 3 spd, floors rusted, 1/4 panels rusted, needs top, \$450. Bill Wisser, 12 Magna Drive, Coplay PA 18037 (215) 262-6555.

Send your ads to the editor.
(include full description- year,
body style, 2 or 4 door, color,
engine, tranny, price, etc.)

CARS WANTED:

1964 or 1965 Falcon hardtop or Ranchero. No rust or body putty, V8 standard or auto. Will pay good price for right car. Richard Grant, R.D. #5 Box 190, Jersey Shore, PA 17740 (717) 398-2543 after 4:00 p.m.

PARTS FOR SALE:

63 conv top switch \$25, 63 conv door and 1/4 panel moldings \$15 ea, 63 dash pad molding \$10, 64 conv rear seat bottom \$20, 64 conv ash tray panels \$50 pr, 63 conv windshield (tinted) g.c. \$100, 63 front bumper \$40, 65 steering linkage (8 cyl) \$25, 64 steering linkage (6 cyl, P/S) \$25, 66 Mustang 8 cyl P/S system \$150, 63-64 Ht doors \$65 each. Bill Wisser, 12 Magna Drive, Coplay PA 18037 (215) 262-6555.

For 1966 & 67: grilles \$60, headlight doors \$20 each, fenders \$40 each, hoods \$40, trunk lids \$35, taillights complete \$20 each, heaters complete \$25 each, gas tanks \$40, radiators \$75, 3 speed trans \$75, driveshafts \$20, 5 lug 8 inch rear \$100, 4 lug rear \$75, doors \$35 each, 66 Ranchero doors \$50 each, 67 Futura 2 tone blue seats, door and rear panels, excellent condition, complete \$175, many other 66 & 67 parts. Tim Marks, Elverson, PA (215) 286-5861.

1960-65 doors \$50 up, hoods \$20 up, fenders \$50 up, glass \$10 up, interior parts 1964-65 black padded dash mint \$125, 63 consoles \$45 up, 260 motors \$100 up, 289 motors \$150 up, trannys \$50 up, V8 rears \$150, 6 cyl \$75, 5 bolt bells \$100, Dagenham 6 cyl 4 speed good shape \$325, hardtop buckets \$150 set, bench seats \$50 up, 9 inch rear 52 inch \$200, many more parts available. George Rokita, R.D.#3 Box 167, Elverson PA 19520. (215) 286-0299.

Send your ads to the editor.
(Please indicate a price for
each item offered.)

PARTS WANTED:

64 Sprint chrome valve covers, 64 console (turq), 4 spd black shifter knob, 64 bucket seat set (turq), idler arm bushing P/S. Bill Wisser, 12 Magna Drive, Coplay PA 18037 (215) 262-6555.

SERVICES RECOMMENDED:

ANNUAL DINNER REPORT:

A total of 47 members and friends attended our third annual dinner at Meyers' Family Restaurant in Quakertown on March 16th:

Ted & Cathy Carman
Dave Carson
Marin Ennis
Rudy & Linda Gross
Earl Hess
Richard Hostetler & Paula Seibert
Roy & Elizabeth Hunsberger
Bruce & Joan Kichline
Jerry Kratz, Sr.
Jerry & Linda Kratz
Harold Krause & Pat Zentner
Glenn & Barbara Kuhn
Jim & Shirley Lape
Jim & Donna Larkin
Ed Melefsky
Kurt & Berti Otten
Chris & Gerrie Scioscia
Matt, Mary & William Scioscia
Ginny & Frank Servas
Ed & Nancy Snyder
Todd Spencer
Robert & Bonnie Weikert
Jeff Wied
Walt & Esther Wied
Chester & Rebecca Wisneski
Bill & Linda Wisser
Bruce & Pam Wolfe

Those who attended enjoyed an "all you can eat" meal of Dutchess soup, salad, roll, glazed carrots, green beans almondine, sliced turkey and ham, and desert. Afterward, during the business meeting reports were made by the officers, and future chapter events were discussed. The tapes of our Grantville meet and the recent Spare Parts program that Marin appeared on were shown. The pleasant evening concluded around 10 p.m.

Special thanks are due to many for making this evening possible:

Ed Snyder for organizing the event.

Marin Ennis for the tape of the program.

Dr. Richard Derstine (Rockhill Animal Hospital) for pens and screwdrivers.

North Penn Auto Parts, Perkasie for polishing cloth.

Yokum Auto Electric, Sellersville for an ampere meter.

Snap On for beach towels, hats and calendars.

MAC Tools for sunglasses, tee shirt, hat and calendar.

Mrs. Esther Wied for the hand crocheted kitchen towels.

Bill & Linda Wisser for the Keystone napkins, hand-made keystone shaped mint table favors and perfume.

Harold Krause for Ford hat, powered by Ford plaque, and other memorabilia.

Ridge Auto for Battery Pro hats.

Treasurer's report for our third year through 12/31/90.

Balance on Hand 12/31/89		448.24
Income:		
Dues for 17 new members	85.00	
Renewals	260.00	
Reinstatement	5.00	
Extra Contributions	88.00	
50/50 Raffle	24.00	
Dinner Receipts	560.00	
Deposit (1989) refund	50.00	
Profit from Chapter Store	117.00	
Drive-In Award	50.00	

Total		1239.00
Expenses:		
Envelopes and postage for newsletters	137.24	
Dinner Expenses	557.25	
Dinner (1991) Deposit	80.00	
Canopy for meets	39.95	
Coffee Pot	39.00	

Total		853.44
Balance on Hand 12/31/90		833.80

1965 Direction Signals

"Standard" Bulb No.	"Heavy Duty" Bulb No.
1034	1157 (White), 1157A (Amber)
1073	1156
67	1155
57	1895
89	631

348 SEAT BELT RETRACTOR BREAKAGE

(1965 Falcon with Bucket Seats)

Seat belt retractor breakage may occur on some 1965 Falcon vehicles equipped with bucket seats. The breakage results from interference between the retractor and seat back pivot arm when the seat belt boot is rotated to the full forward position and the seat is actuated forward for entrance to the rear seat.

The problem will be corrected on 1966 vehicles with the initial release of a new enclosed retractor design.

The interference condition should be corrected on a customer complaint basis by adding a stop to the forward rotation of the seat belt boot as follows:

Add a 9/16 hole in the door sill 2-9/16 inches ahead of and 15/32 inches above the seat belt attaching bolt, and add a rubber bumper (#358939-S) to act as a boot stop. (See Fig. 13.)

WARRANTY STATUS - REIMBURSABLE
Oper. SP-61200-A-65

Time: 0.3 hrs.

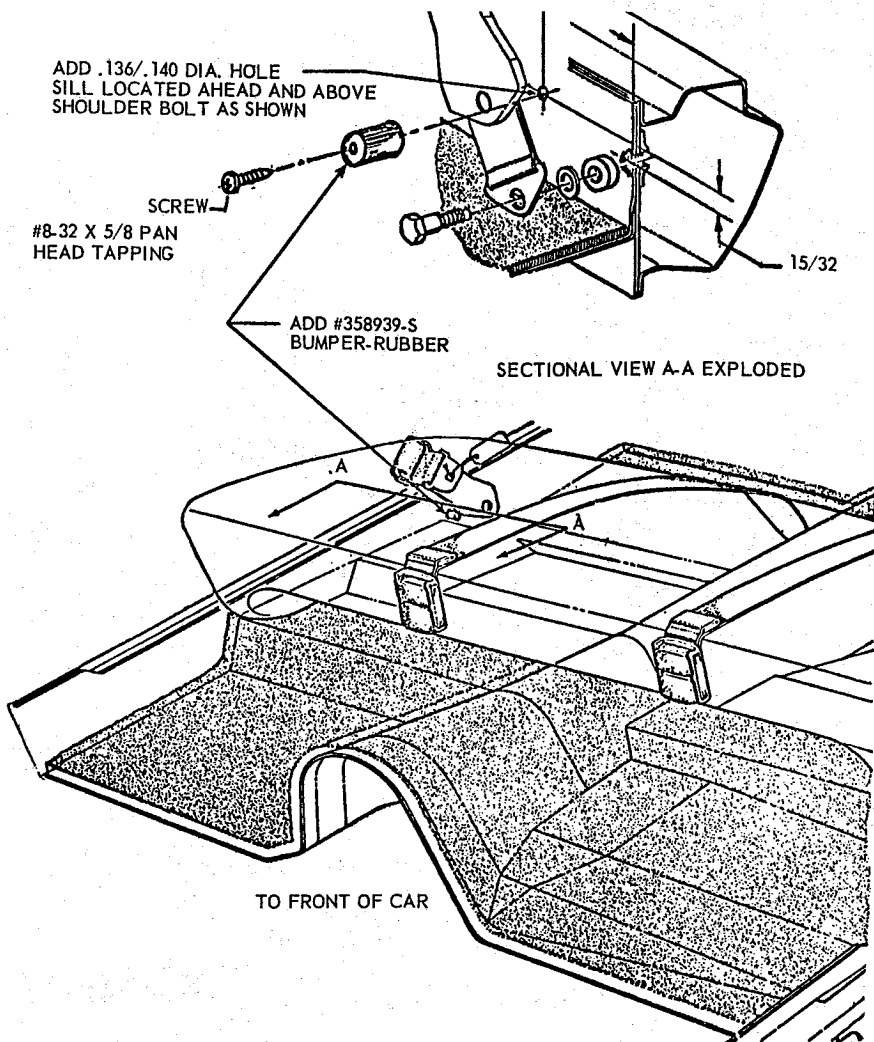
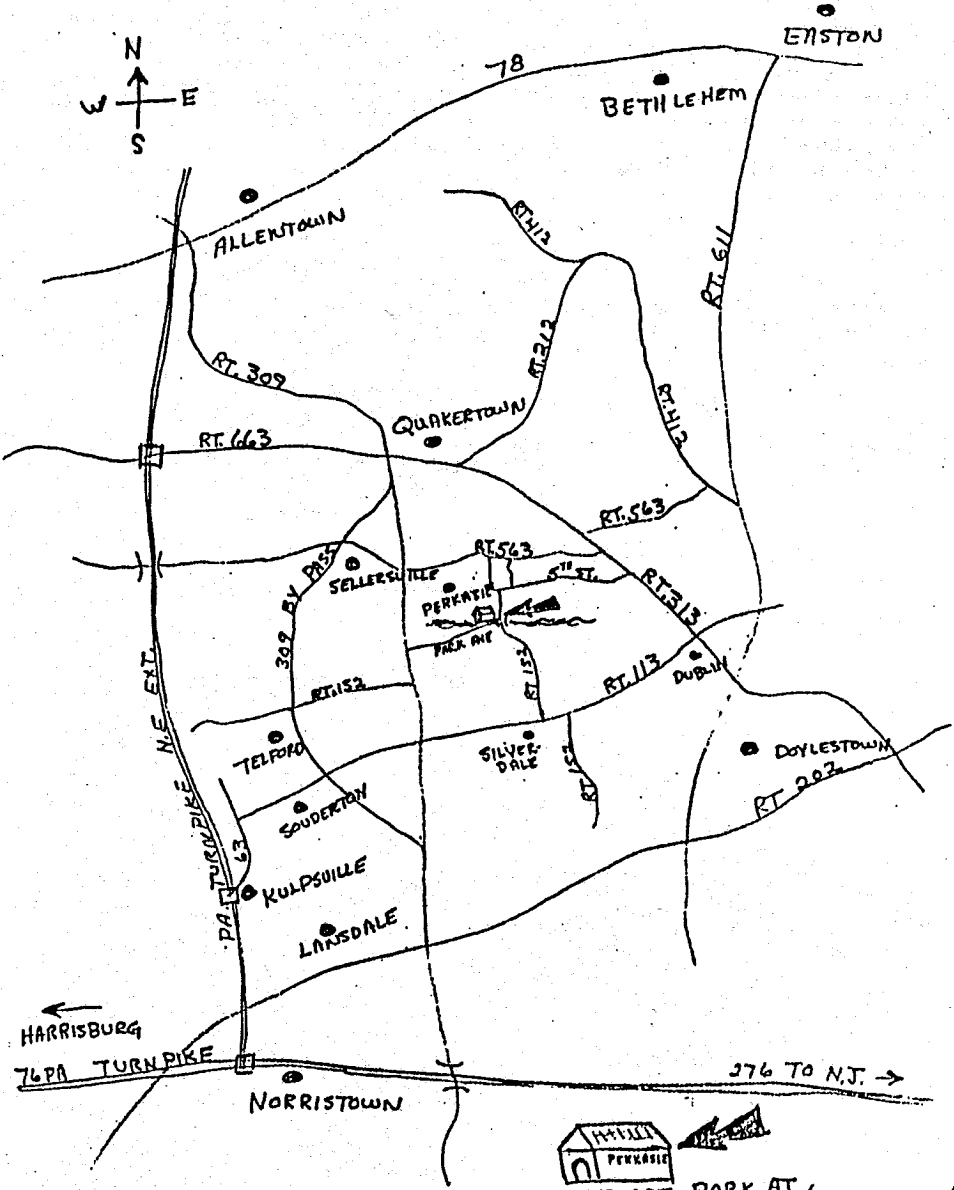

Fig. 13 - Seat Belt Retractor Breakage - 1965 Falcon - All With Bucket Seats (Article 348)

AREA MAP: LAKE LENAPE PARK



LAKE LENAPE PARK AT
COVERED BRIDGE — (WALNUT ST /
PARK AVE)